



CHAP. 1 | 1E

MOTOR VEHICLE INDUSTRY

Body Assembly CMC - Clever Modular Concept

TEXALIS | CARDEL

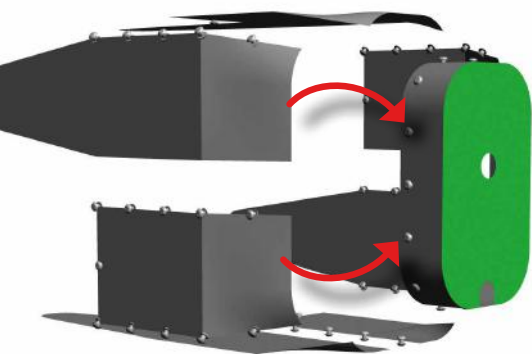

Tear-proof and electrical insulator

Limit adhesion of splatter

Fire-proof class M1

Resist water and oil leaks, etc.

Patented solution



Guaranteed
silicon free



Management
System
ISO 9001:2015

www.tuv.com
ID 1100017006



Multiple advantages :

- . One-piece cover consisting of several panels and adjustable to all types of welding guns
- . Intuitive installation and removal without tools in less than 10 seconds
- . Manufacture with a single seam for better overall resistance to weld splatter
- . Side panels connected to the front face to make removal of the cover easier.



TEXALIS

Aramid texture | Coating with a Aluminized rubber on one face and green rubber on the other



Guaranteed silicon free



Waterproof



Double side coating



Fire class M1



Washable



Repairable



Ripstop



Aramid basis fabric



Guaranteed halogen free



REACH compatible



RoHS 2

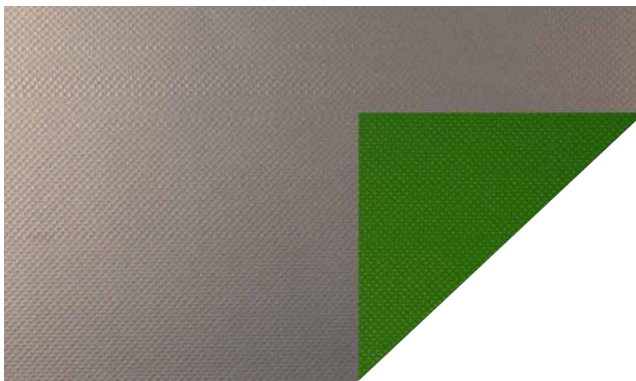

CARDEL

Aramid texture | Coating with a green rubber on one face and black rubber on the other



Guaranteed silicon free



Double side coating



Fire class M1



Washable



Repairable



High level of spark resistance



Aramid basis fabric



Ripstop



Guaranteed halogen free



REACH compatible



RoHS 2

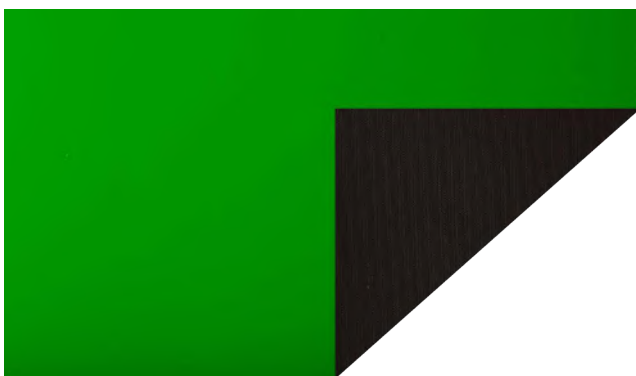



CHAP. 1 | 2B

MOTOR VEHICLE INDUSTRY

Fitting work

TIFFON-R | TKS ALU | TEXALIS

Spark machining / Torch welding / Tücker pin welder / Laser welding



- M1 class flameproofed fabric
- High tearing strength
- Excellent resistance to spattering



Management System
ISO 9001:2015



www.tuv.com
ID 1100017006

MOTOR VEHICLE INDUSTRY | Fitting work

The technical fabrics used feature specific types of coating that combine flexibility with resistance to weld spattering. Their para-aramid bases provide the excellent mechanical strength required for arc, spot or laser welding.



TIFFON-R

Aramid texture | Coating with golden silicone on one face and a face of a red rubber



Waterproof



Double side coating



Fire class M1



Washable



Repairable



Ripstop



Aramid basis fabric



REACH compatible



RoHS 2

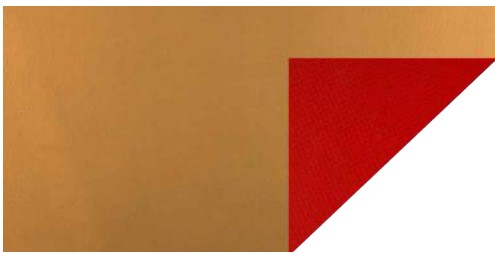

TKS-ALU

Aramid texture | Coating with silicone on one face



Waterproof



One side coating



Fire class M1



Washable



Repairable



Flexible



Aramid basis fabric



REACH compatible



RoHS 2

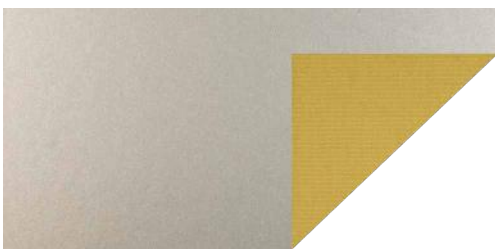

TEXALIS

Aramid texture coating | With a Aluminized rubber on one face and green rubber on the other



Guaranteed silicon free



Waterproof



Double side coating



Fire class M1



Washable



Repairable



Ripstop



Aramid basis fabric



Guaranteed halogen free



REACH compatible



RoHS 2

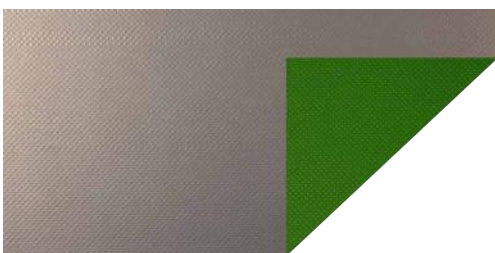



CHAP. 1 | 10A

MOTOR VEHICLE INDUSTRY

Painting Filling Stripping

TORCAL-B | TPSN

Stripping dollies



Sealed cover with welded seams

Ventilated or pressurised solution

Covers made in 1, 2 or 3 parts



Guaranteed silicon free



Management System
ISO 9001:2015

www.tuv.com
ID 1100017006



MOTOR VEHICLE INDUSTRY | Painting Filling Stripping



« High Tech » ASP covers are made from coated technical fabrics. This ensures excellent technical resistance to high-pressure stripping or washing processes and enables the covers to last several years. While meeting your constraints, the « tailor-made » designs ensure maximum efficiency without limiting robot movements. The dry air ventilation/pressurization system optimizes protection results. The time required to replace a cover remains compatible with your productivity.

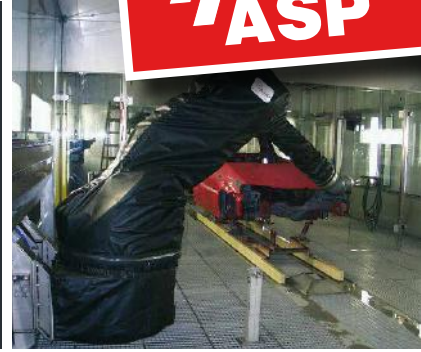

TORCAL-B

Polyamid texture | Coating with an blue rubber on the one face



Guaranteed silicon free



Waterproof



Double side coating



ATEX painting



Waterproof with welded seams



Washable



Repairable



Ripstop



REACH compatible



RoHS 2

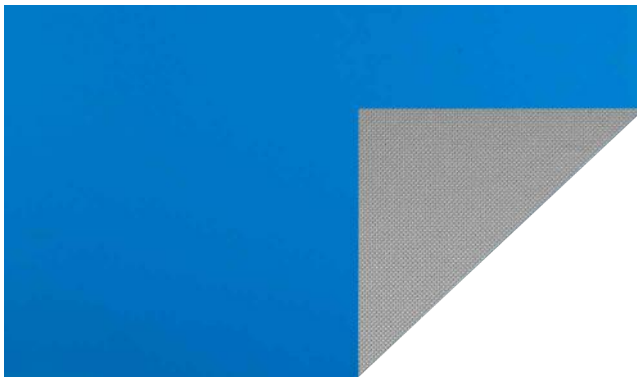

TPSN

Polyester texture | Coating with a black rubber on two faces



Guaranteed silicon free



Waterproof



Double side coating



Waterproof with welded seams



Washable



Repairable



REACH compatible



RoHS 2





CHAP. 2 | 11B

AERONAUTICS

Shot blasting / sand blasting

TLA | T1A | TORCAL-B



Specifically designed for shot blasting
Assembled by cold vulcanization
Specific, specially adapted cover shapes
Covers that can be repaired and
pressurised



Management
System
ISO 9001:2015



www.tuv.com
ID 1100017006

AERONAUTICS | Shot blasting / sand blasting

Washable ASP covers are made from specific technical materials. This ensures excellent resistance during surface treatment operations and enables the covers to last several years. While meeting your constraints, the « tailor-made » designs ensure maximum efficiency without limiting robot movements. Whether the robots are fully integrated in the booth or work through a window, ASP can provide original solutions that are tried and tested.



TLA

Black natural rubber



Guaranteed silicon free



Waterproof



Washable



Repairable



Stretching



T1A

Technical white rubber TPE | Thickness 1 mm



Guaranteed silicon free



Waterproof



Waterproof with welded seams



FDA Certified



REACH compatible



RoHS 2



TORCAL-B

Polyamid texture | Coating with an blue rubber on the one face



Guaranteed silicon free



Waterproof



Double side coating



ATEX painting



Waterproof with welded seams



Washable



Repairable



Ripstop



REACH compatible



RoHS 2





CHAP. 3 | 23B

FOOD GRADE

Cheese and Dairy Plant

TEXPRAL-B | T1A

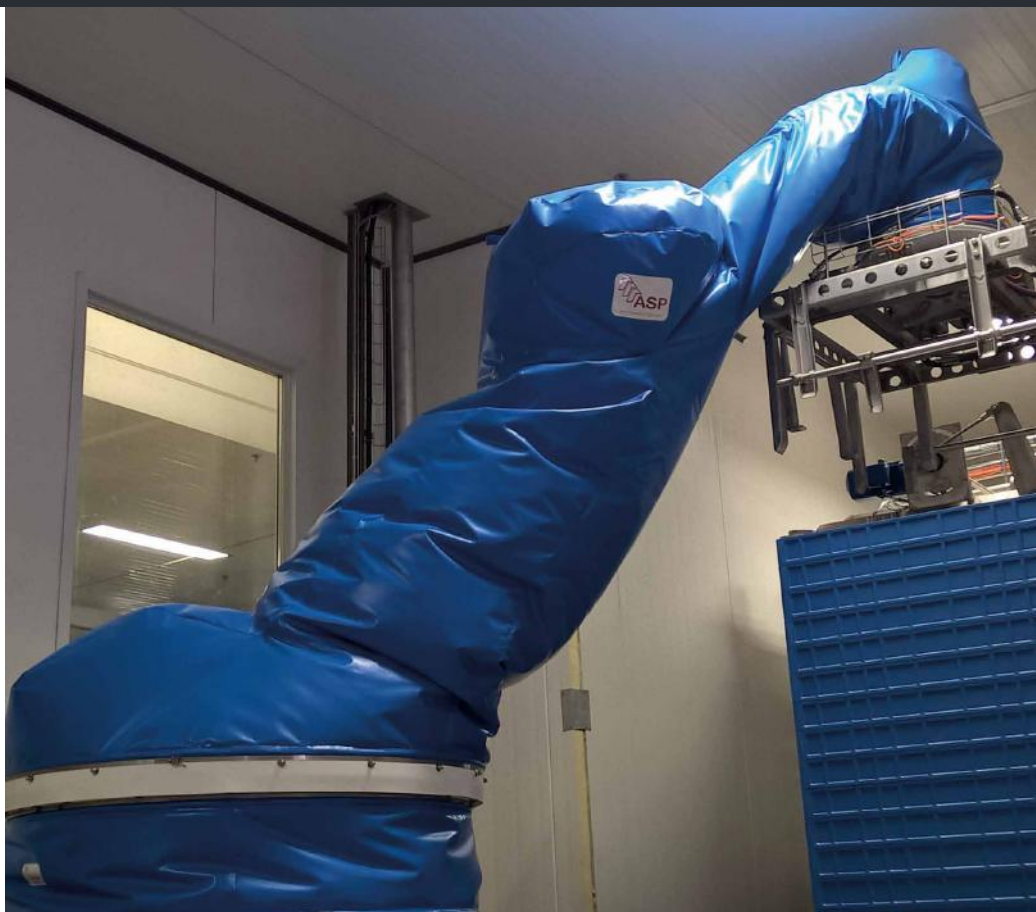

Certified FDA fabric (Food and Drug Administration)

Washable cover directly on the robot

The cover can be ventilated / pressurised



Management System
ISO 9001:2015



www.tuv.com
ID 1100017006

ALIMENTARY | Cheese and Dairy Plant

ASP «High Tech» covers are made from technical fabrics coated on both sides. This ensures excellent resistance to high-pressure stripping or washing processes and enables the covers to last several years. While meeting your constraints, the «tailor-made» designs ensure maximum efficiency without limiting robot movements. The optional dry air ventilation/pressurization system optimizes protection results.



TEXPRAL-B

Polyamid texture | Coated one side with a blue thermoplastic



Guaranteed silicon free



Waterproof



Double side coating



Waterproof with welded seams



Washable



Repairable



FDA Certified



Ripstop



Guaranteed halogen free



REACH compatible



RoHS 2



T1A

Technical white rubber TPE | Thickness 1 mm



Guaranteed silicon free



Waterproof



Waterproof with welded seams



FDA Certified



REACH compatible



RoHS 2

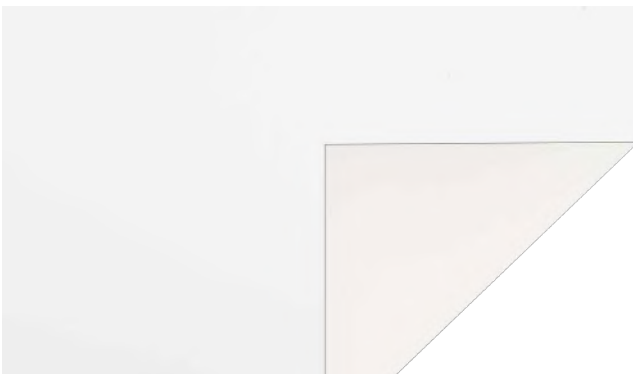



CHAP. 3 | 23C

FOOD GRADE

Slaughterhouse

TEXPRAL-B | T1A



Certified FDA fabric (Food and Drug Administration)

Washable cover directly on the robot

The cover can be ventilated / pressurised



Management System
ISO 9001:2015



www.tuv.com
ID 1100017006

ALIMENTARY | Slaughterhouse

ASP «High Tech» covers are made from technical fabrics coated on both sides. This ensures excellent resistance to high-pressure stripping or washing processes and enables the covers to last several years. While meeting your constraints, the «tailor-made» designs ensure maximum efficiency without limiting robot movements. The optional dry air ventilation/pressurization system optimizes protection results.



TEXPRAL-B

Polyamid texture | Coated one side with a blue thermoplastic



Guaranteed silicon free



Waterproof



Double side coating



Waterproof with welded seams



Washable



Repairable



FDA Certified



Ripstop



Guaranteed halogen free



REACH compatible



RoHS 2

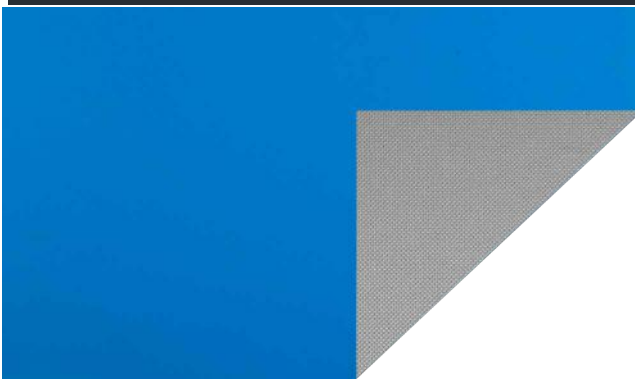

T1A

Technical white rubber TPE | Thickness 1 mm



Guaranteed silicon free



Waterproof



Waterproof with welded seams



FDA Certified



REACH compatible



RoHS 2

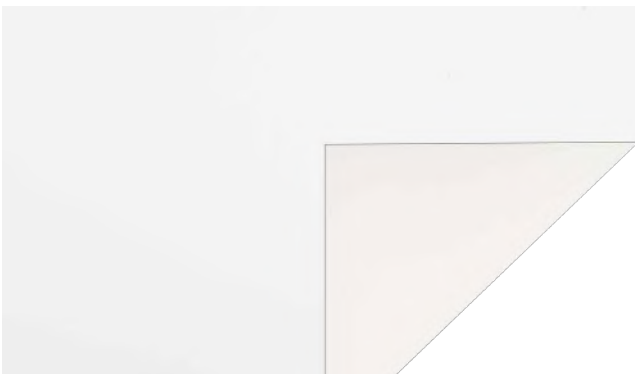



CHAP. 4 | 15B

GENERAL INDUSTRY

Forging Die casting

TIFFON-R Pressure Die Casting / Stamping

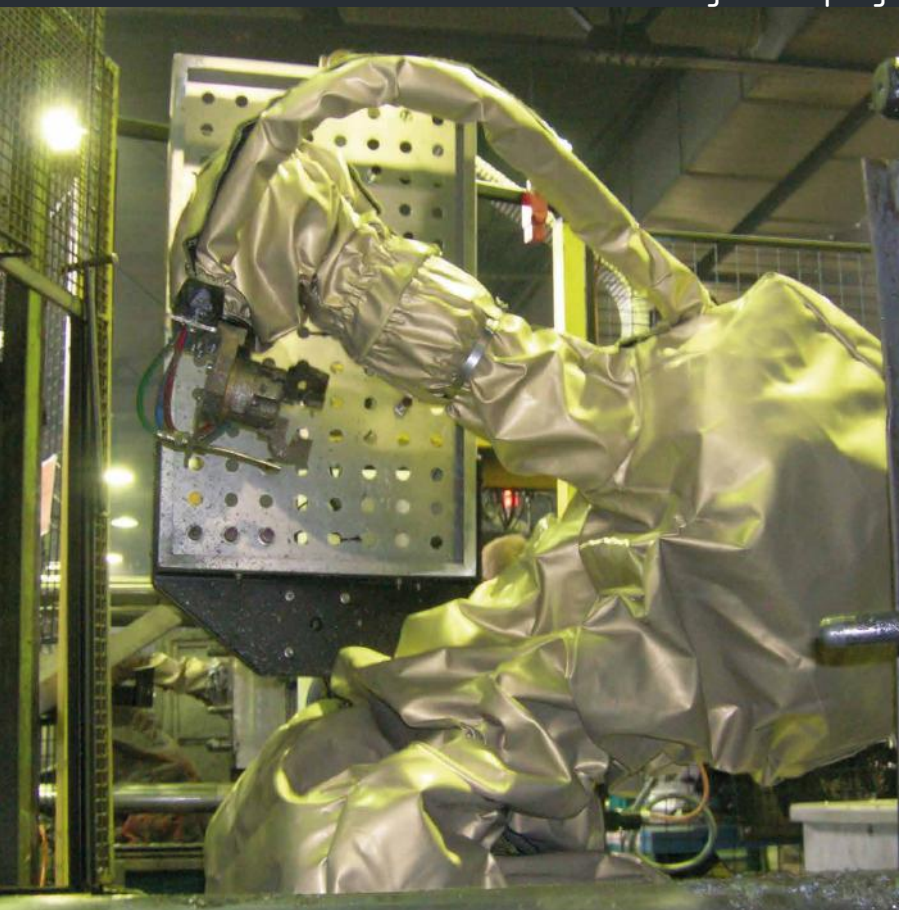

High tearing strength

M1 class flameproofed fabric

Stands up to aluminium,
brass, magnesium...



Repairable



Management
System
ISO 9001:2015



www.tuv.com
ID 1100017006

GENERAL INDUSTRY | Forging Die casting

In their « die casting » version, ASP covers use coated technical fabrics (aramid base). The specific coatings give the complexes the mechanical and thermal properties required for this type of process (flameproofing classification, tearing strength). The « tailor-made » designs and the possibility of repairing used covers in our workshops ensure optimum protection for your robots.



TIFFON-R

Aramid texture | Coating with golden silicone on one face and a face of a red rubber



Waterproof



Double side coating



Fire class M1



Washable



Repairable



Ripstop



Aramid basis fabric



REACH compatible



RoHS 2





CHAP. 4 | 16B

GENERAL INDUSTRY

Foundry

TELUPRO

Lost-wax casting / Preparing cores / Unloading shot blasting machines



Multi-purpose fabric
High strength

Protected seams

Short fitting and removal times



Management System
ISO 9001:2015



www.tuv.com
ID 1100017006

GENERAL INDUSTRY | Forging Die casting

In their « die casting » version, ASP covers are made with specific coated technical fabrics. This ensures full compatibility with Die casting processes (resistance to abrasion) and enables the covers to last for several years. While meeting your constraints, the « tailor-made » designs ensure maximum efficiency without limiting robot movements.



TELUPRO

Polyamid texture | Coating with a grey rubber



Guaranteed silicon free



Waterproof



One side coating



Washable



Repairable



Flexible



ATEX painting



REACH compatible



RoHS 2

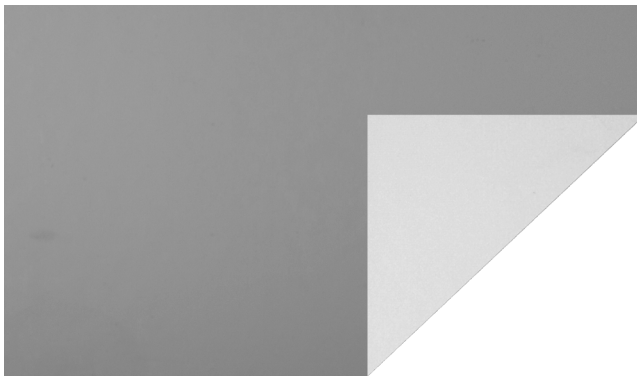



CHAP. 4 | 17

GENERAL INDUSTRY

Machining Cutting

TPSN
Machine department



Excellent resistance to straight oils

Covers with protected seams

Suitable for high pressure levels



Management
System
ISO 9001:2015



www.tuv.com
ID 1100017006

GENERAL INDUSTRY | Machining Cutting

ASP «High Tech» covers are made from technical fabrics coated on both sides. This ensures excellent resistance to high-pressure stripping or washing processes and enables the covers to last several years. While meeting your constraints, the «tailor-made» designs ensure maximum efficiency without limiting robot movements. The optional dry air ventilation/pressurization system optimizes protection results.



TPSN

Polyester texture | Coating with a black rubber on two faces



Guaranteed silicon free



Waterproof



Double side coating



Waterproof with welded seams



Washable



Repairable



REACH compatible



RoHS 2





CHAP. 4 | 18A

GENERAL INDUSTRY

Machining Cutting

TELUPRO

Water jet cutting / Handling



A simple, reliable solution

Stands up well to lubricants

Seams protected if necessary



Management System
ISO 9001:2015



www.tuv.com
ID 1100017006

GENERAL INDUSTRY | Machining Cutting

ASP «machining» covers are made from specific coated technical fabrics. This ensures full compatibility with Die casting processes (resistance to abrasion) and enables the covers to last for several years. While meeting your constraints, the «tailor-made» designs ensure maximum efficiency without limiting robot movements.



TELUPRO

Polyamid texture | Coating with a grey rubber



Guaranteed silicon free



Waterproof



One side coating



Washable



Repairable



Flexible



ATEX painting



REACH compatible



RoHS 2

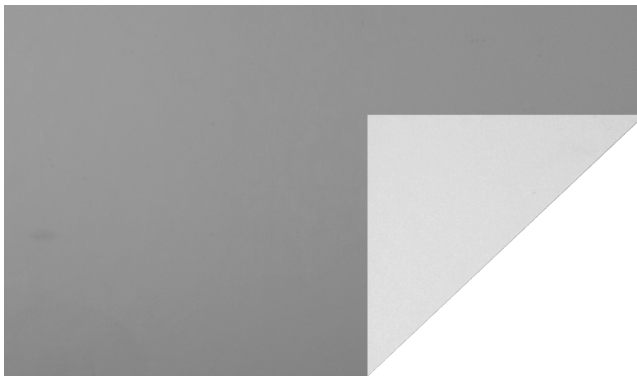



CHAP. 4 | 19B

GENERAL INDUSTRY

HP deburring

TORCAL-B



Excellent resistance to straight oils

Covers with protected / sealed seams

High pressure processes at up
to 2,000 bars



Management
System
ISO 9001:2015



www.tuv.com
ID 1100017006

GENERAL INDUSTRY | HP deburring

ASP «High Tech» covers are made from technical fabrics coated on both sides. This ensures excellent resistance to high-pressure stripping or washing processes and enables the covers to last several years. While meeting your constraints, the «tailor-made» designs ensure maximum efficiency without limiting robot movements. The optional dry air ventilation/pressurization system optimizes protection results.



TORCAL-B

Polyamid texture | Coating with an blue rubber on the one face



Guaranteed silicon free



Waterproof



Double side coating



ATEX painting



Waterproof with welded seams



Washable



Repairable



Ripstop



REACH compliant



RoHS 2

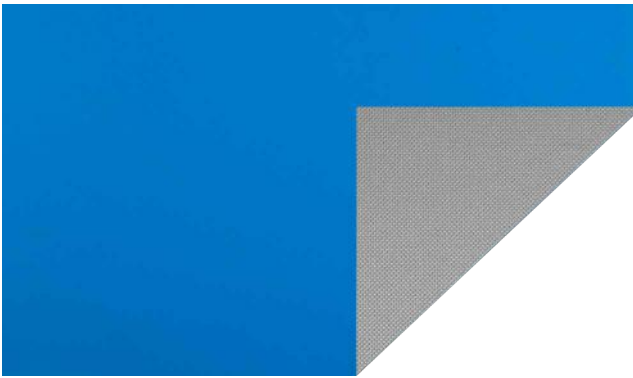



CHAP. 4 | 20

GENERAL INDUSTRY

HP deburring FST solution

TPSN



An original solution for the first booths
Adapts to suit all robot cycles
Length adjustment during the first cycle
Patented solution



Management System
ISO 9001:2015



www.tuv.com
ID 1100017006

GENERAL INDUSTRY | HP deburring FST solution

The FST solution does away with the necessity of developing window type covers. Thanks to its patented «bellows» principle, the cover adjusts to suit the robot cycles right from the initial trajectory. This means that the cover is free of water pockets and is never under tension. Used in association with fabrics that have shown their considerable flexibility of use; the FST solution provided by ASP has become a standard reference in High Pressure cleaning processes.



TPSN

Polyester texture | Coating with a black rubber on two faces



Guaranteed silicon free



Waterproof



Double side coating



Waterproof with welded seams



Washable



Repairable



REACH compatible



RoHS 2





CHAP. 4 | 24

GENERAL INDUSTRY

Foundry

TKS ALU Aluminium Press



M1 class flameproofed fabric

Protected seams if required

**Our range can reach temperatures
between 250 ° C and 1200 ° C**

(Depending on the duration of exposure)



Management
System
ISO 9001:2015



www.tuv.com
ID 1100017006

GENERAL INDUSTRY | Foundry

In their « foundry » version, ASP covers use coated technical fabrics (aramid base). The specific coatings give the complexes the mechanical and thermal properties required for this type of process (flameproofing classification, tearing strength). The « tailor-made » designs and the possibility of repairing used covers in our workshops ensure optimum protection for your robots.



TKS-ALU

Aramid texture | Coating with silicone on one face



Waterproof



One side coating



Fire class M1



Washable



Repairable



Flexible



Aramid basis fabric



REACH compatible



RoHS 2





VENTILATION PRESSURISATION

Ventilation system For robot cover

SOLUTION

Ventilated Open Solution

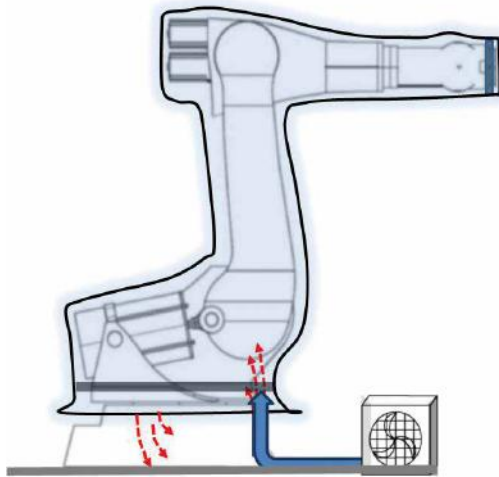

Ventilated cover

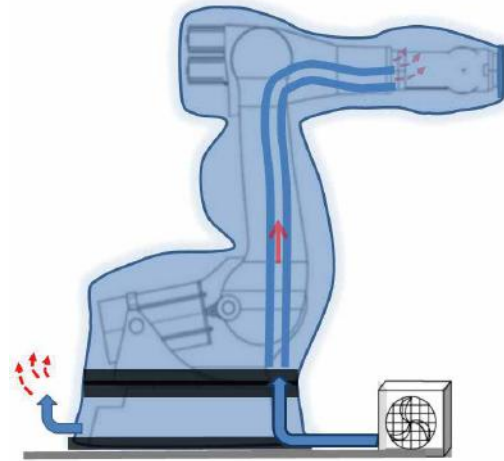

< 2 mbar

TEMPERATURE REGULATION

Yes

Limit maximum pressure

PRESSURE REGULATION

No

Yes

The installation is sized for each customer (by calculation)

Anti Condensation



Management System
ISO 9001:2015



www.tuv.com
ID 1100017006

VENTILATION PRESSURISATION | Ventilation system for robot cover



The fan provides a permanent air circulation that keeps the robot dry. The volume of air is renewed preventing moisture from condensing inside the cover.



VENTILATION GROUP I Developed for robot covers

4 versions

Q (m ³ /h)	PT (total pressure)	Ventil 0	Ventil 1	Ventil 2	Ventil 3
280	390	X			
900	800		X		
450	1 000			X	
620	1 900				X

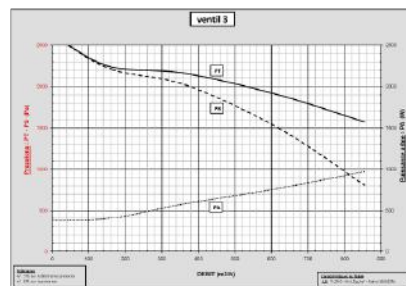
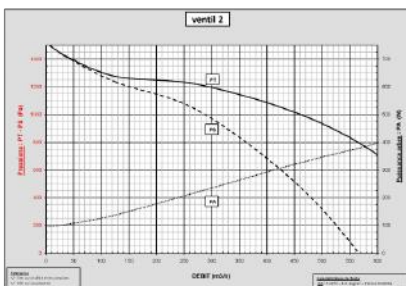
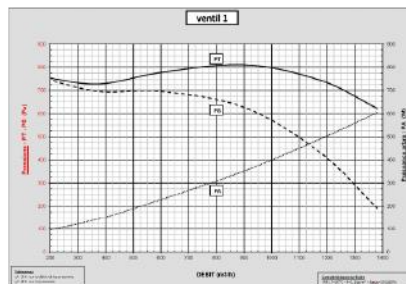
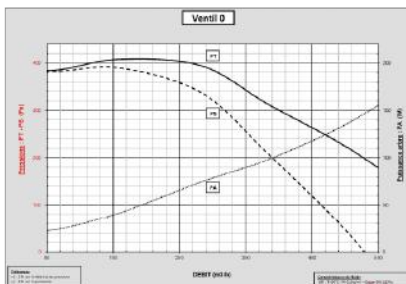

Acier peint (Inox en option)

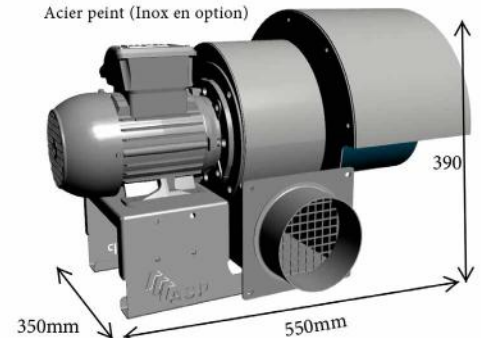

Class F motor, IP55,
50Hz 230 / 400v three-phase

With filter

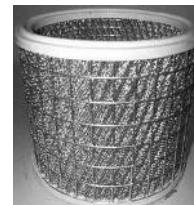

Oil



Dust

Option

- 10 / Clogging filters
- 20 / Frequency converter + pressure sensor
- 30 / Frequency converter + T ° sensor
- 40 / Clogging filter + frequency variator + pressure sensor
- 50 / Clogging filter + frequency variator + T ° sensor
- 60 / ATEX
- 70 / ATEX + frequency inverter + pressure sensor
- 80 / ATEX + Clogging filters + frequency variator + pressure sensor

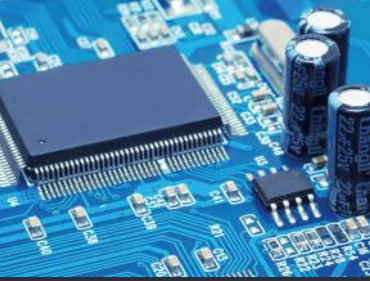

CHAP. 6 | 27

HIGH-TECH SOLUTION

ATEX (explosive atmospheres)
solution

TATEX



Zone 1 or 21 Certifiable solution

Group II and III (A, B and C)
compatible conductive fabric

Protected cover



Management
System
ISO 9001:2015



www.tuv.com
ID 1100017006

HIGH-TECH SOLUTION | ATEX solution

ASP's «ATEX» solutions are made from specific materials and fabricated in compliance with ATEX directive 2014/34/EU. The ground braiding ensures that the cover remains electrically neutral. The «Custom» Design offers maximum efficiency while complying with your constraints and requirements and without restricting robot movement. The ventilation/pressurization option optimizes protection performance. Covers repaired in our workshops provide resilient and long-lasting protection for your robots.



TATEX

Polyester texture | Coating with a black antistatic rubber



Guaranteed silicon free



Waterproof



One side coating



ATEX electronic



ATEX painting



Waterproof with welded seams



Guaranteed halogen free



REACH compatible



RoHS 2

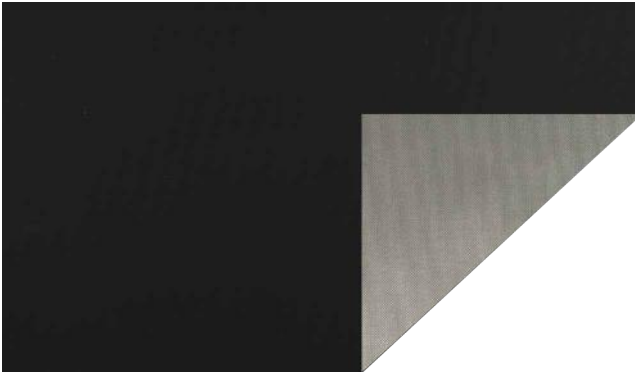

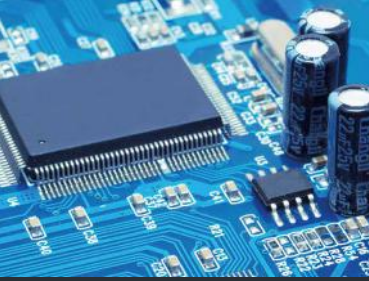

CHAP. 6 | 28

HIGH-TECH SOLUTION

CLIM - 40°C / + 90°C solution

TKS-ALU | TP62



Multiple-layer insulating cover to impede heat transfer

Cover with reinforced seal

Rotating rings for axis 1 and axis 4 with built-in air flow

Specific air handling system with integrated dehydrator



Management System
ISO 9001:2015



www.tuv.com
ID 1100017006

HIGH-TECH SOLUTION | CLIM -40°C / +90°C solution

ASP's «CLIM -40°C / +90°C» solutions are made from specific materials (fabric, and accessories). They are developed and produced in constant pursuit of the lowest possible thermal conductivity. The «Custom» Design offers maximum efficiency while complying with your constraints and requirements with minimum restriction to robot movement. The dry-air ventilation/ pressurisation system guarantees highly efficient protection. Covers repaired in our workshops provide resilient and long-lasting protection for your robots.



TKS-ALU

Aramid texture | Coating with silicone on one face



Waterproof



One side coating



Fire class M1



Washable



Repairable



Flexible



Aramid basis fabric



REACH compatible



RoHS 2



TP62

Polyester texture | Coating with a rubber



Guaranteed silicon free



Waterproof



One side coating



Single use



Flexible



ATEX painting



REACH compatible



RoHS 2



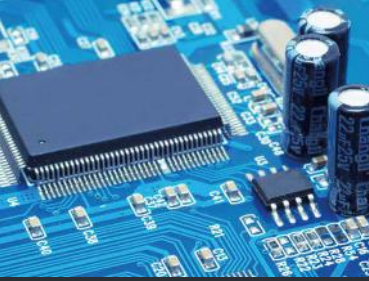

CHAP. 6 | 29

HIGH-TECH SOLUTION

CLIM - 20°C / + 60°C solution

TORCAL-B | TP62



Multiple-layer insulating cover to impede heat transfer

Cover with reinforced seal

Stainless steel/ composite rotating seals on axes 1, 4 and 6

Specific air handling system with integrated dehydrator



Management System
ISO 9001:2015



www.tuv.com
ID 1100017006

HIGH-TECH SOLUTION | CLIM - 20°C / + 60°C solution

ASP's « CLIM -20°C / +60°C » solutions are made from specific materials (fabric, and accessories). They are developed and produced in constant pursuit of the lowest possible thermal conductivity. The « Custom » Design offers maximum efficiency while complying with your constraints and requirements with minimum restriction to robot movement. The dry-air ventilation/ pressurisation system guarantees highly efficient protection. Covers repaired in our workshops provide resilient and long-lasting protection for your robots.



TORCAL-B

Polyamid texture | Coating with an blue rubber on the one face



Guaranteed silicon free



Waterproof



Double side coating



ATEX painting



Waterproof with welded seams



Washable



Repairable



Ripstop



REACH compliant



RoHS 2

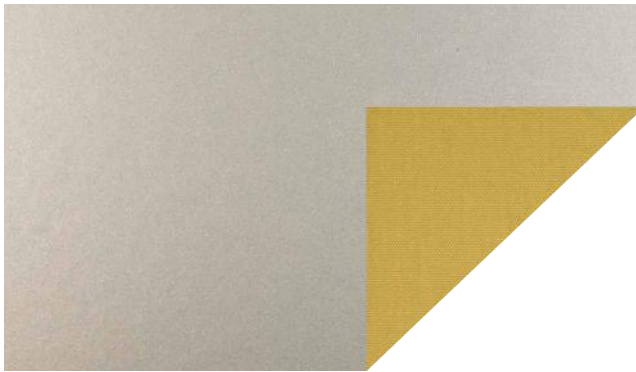

TP62

Polyester texture | Coating with a rubber



Guaranteed silicon free



Waterproof



One side coating



Single use



Flexible



ATEX painting



REACH compliant



RoHS 2

